

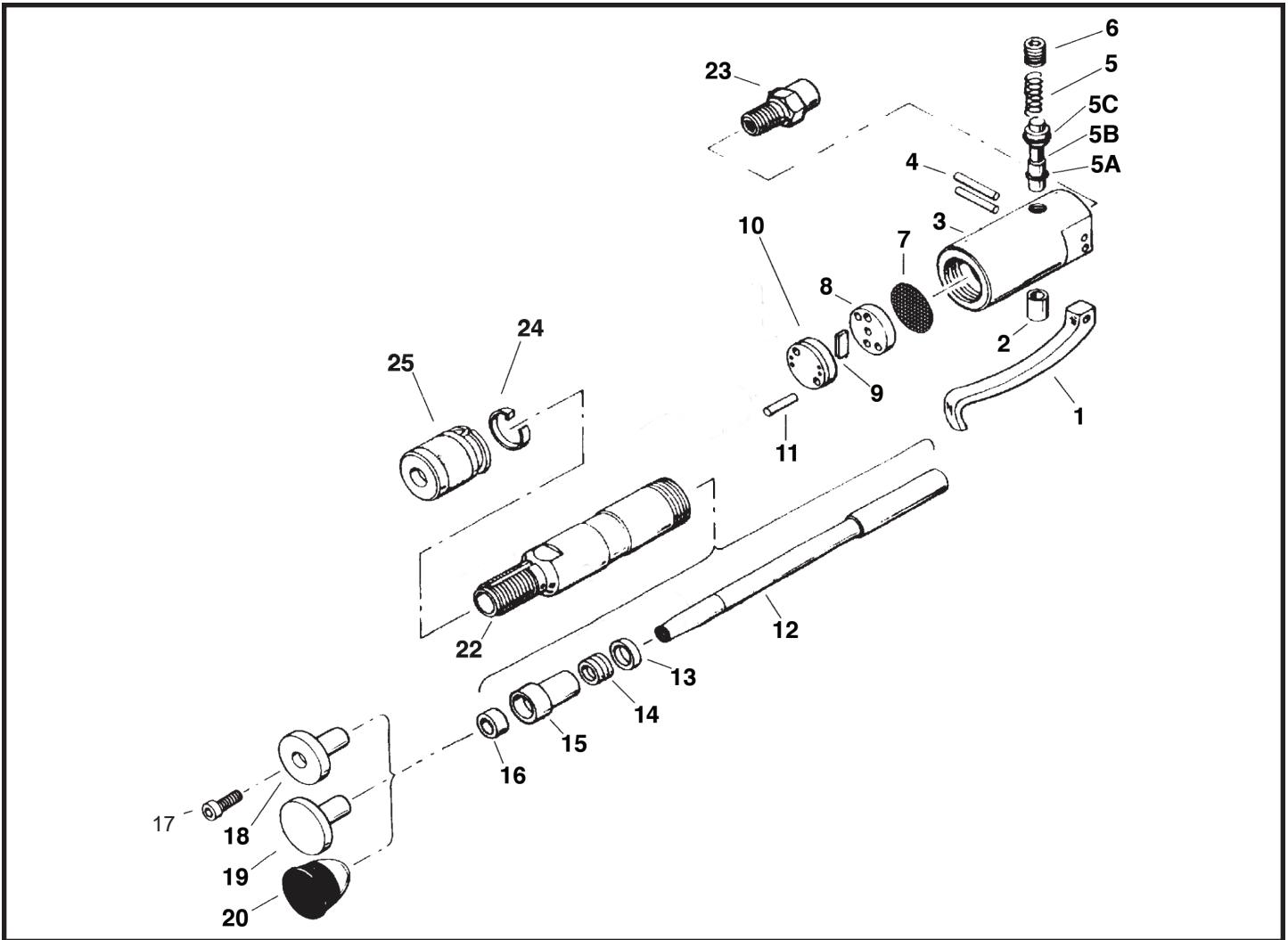

SF-2BAR Rammer



Index	Part No.	Description
1	S5512-H	Lever
2	S5510	Throttle Bushing
3	S5501	Backhead
4	S5513	Lever Pin (2)
5	S5503	Throttle Spring
5A	SC-100	Stem O-Ring
5B	S5511	Throttle Valve
5C		O-Ring
6	S5502	Throttle Plug
7	S5504	Screen
8	S5505	Valve Lid
9	S5507	Valve
10	S5506	Valve Block

Index	Part No.	Description
11	S5508	Valve Dowel (2)
12	S5521	Piston (2-1/2")
13	S5517	Gland Washer
14	S5518	Packing Set
15	S5519A	Packing Gland(2-1/2")
16	S5524	Wiper Seal
17	S5530	Butt Screw
18	SR-5531	Steel Butt (2-1/2")
19	SR-251S	Rubber Butt (2-3/8")
22	S5515	Cylinder (2-1/2")
23	S5514	Screened Inlet
24	S5516	Lock Clip
25	S5520	Packing Nut